



sameror

PRODUCT PORTFOLIO

+50
years

OF EXPERIENCE

1000
delivered

MACHINES

60
export

COUNTRIES

WE SERVE OUR CUSTOMERS IN THE SHEET METAL WORKING INDUSTRY WORLDWIDE BY **CREATING** ADVANCED PRODUCTION SOLUTIONS FOR THE FABRICATION OF HIGH-QUALITY **SHEET METAL PRODUCTS**.
THE **MAIN MACHINE TYPES** OF OURS ARE SHORTLY OVERVIEWED HERE.



SAMESOR METAL ROOF TILE LINES

Samesor lines Metal Roof Tile profiles & panels

- classic roof tile profiles (from ridge to eave)
- modular roof tile panels
- panels/profiles with concealed fixing (e.g. Samesor Z-Lock)
- special profiles & panels

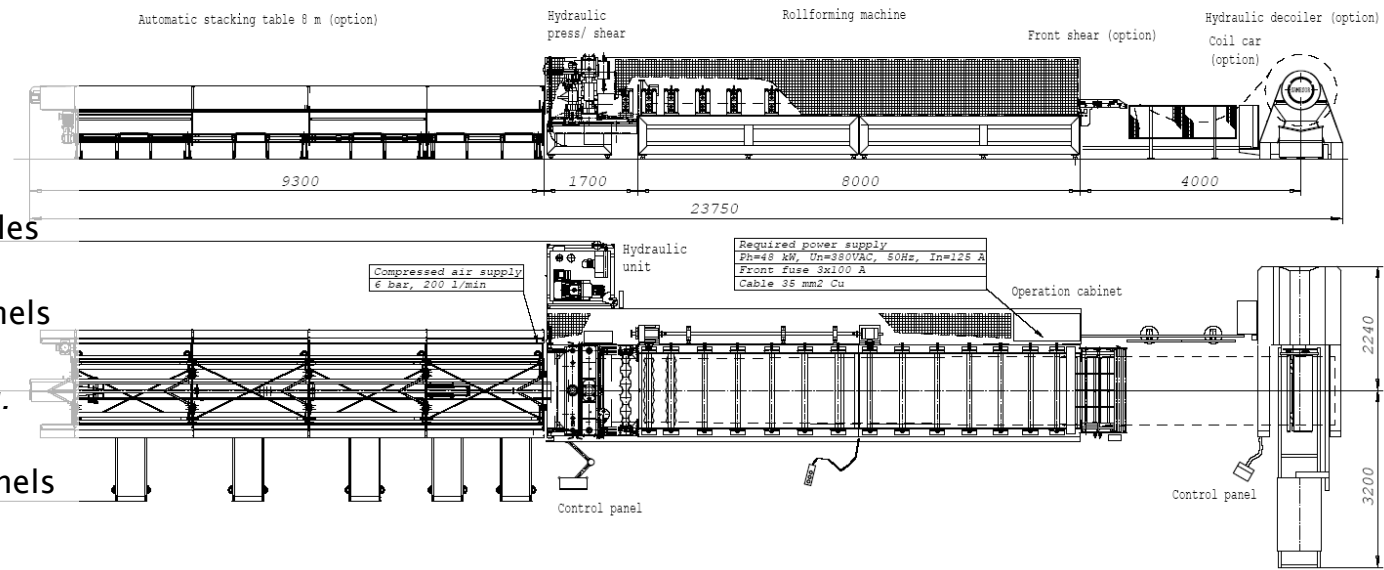

SAMESOR METAL ROOF TILE LINES

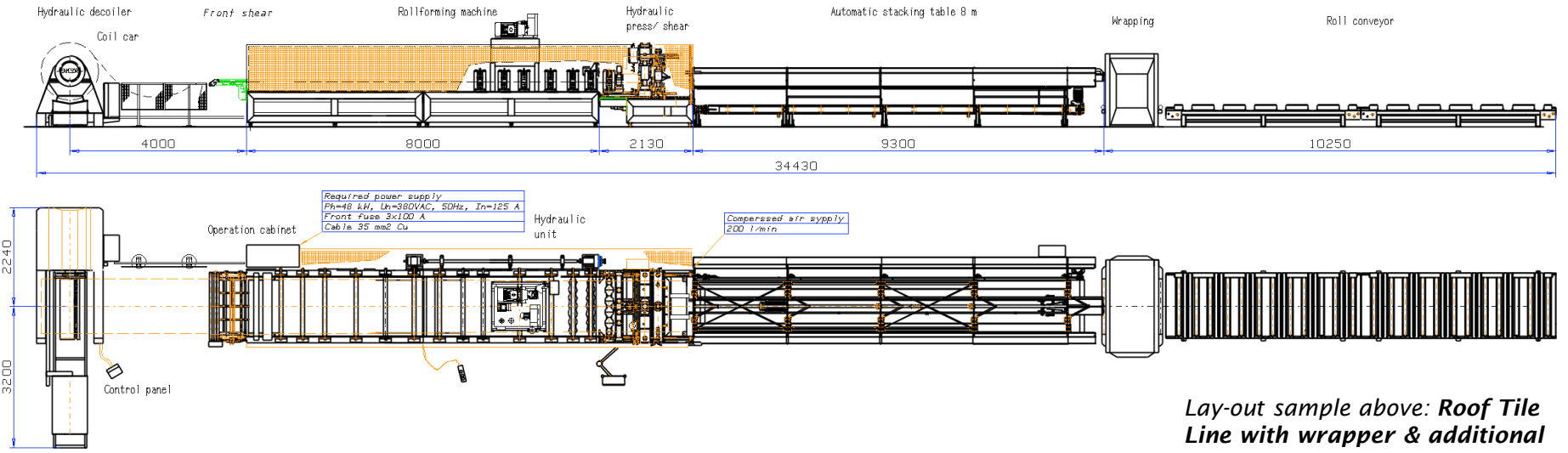

Lay-out sample above: Roof Tile Line with wrapper & additional conveyor



SAMESOR ROOFING, CLADDING & DECKING LINES

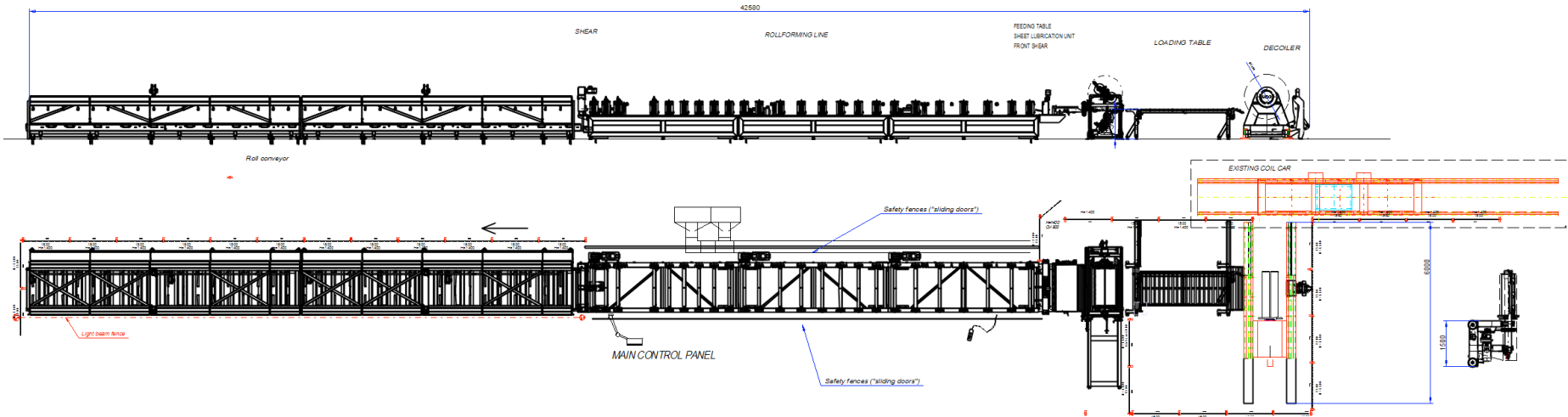

Samesor lines for Roofing/Cladding /Decking profiles

- Trapezoidal profiles, sinusoidal profiles, snap lock profiles

Lay-out sample above:
Single profile line

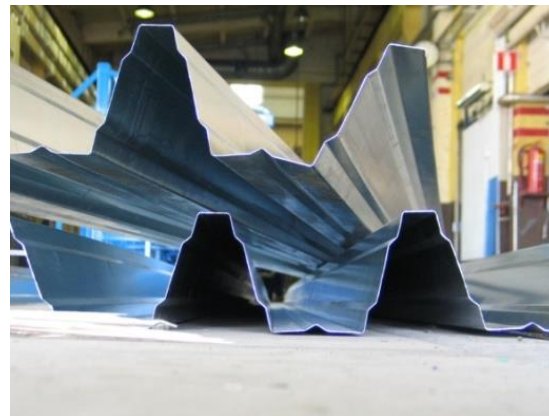
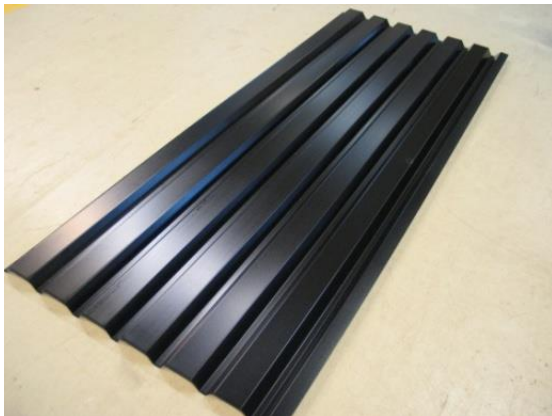

SAMESOR ROOFING, CLADDING & DECKING LINES

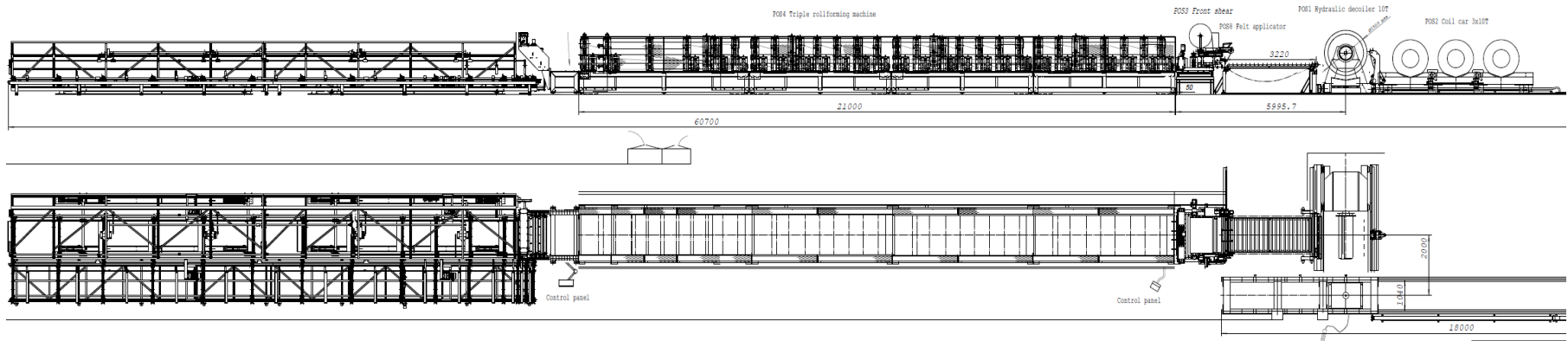

Samesor lines for Roofing/Cladding /Decking profiles

Lay-out sample above: *Triple Decker*

- Single rollformers, Double deckers, Triple deckers



SAMESOR ROOFING, CLADDING & DECKING LINES

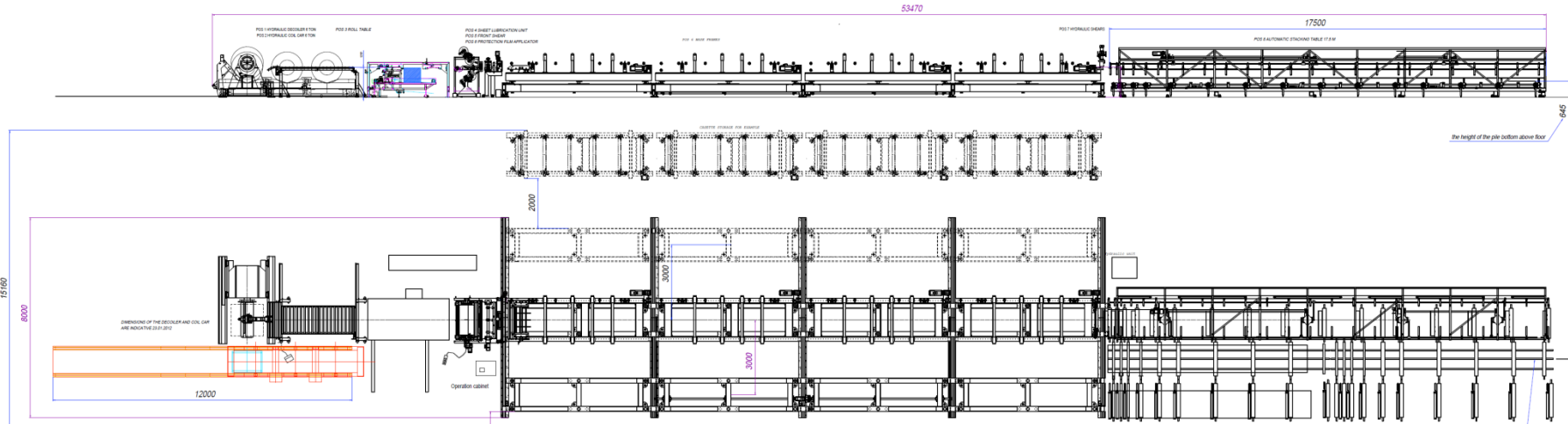

Samesor lines for Roofing/Cladding /Decking profiles

- Rafted profiling lines (cassette change)

*Lay-out sample above:
Quick-change Cassette line*



SAMESOR STEEL FRAMING LINES

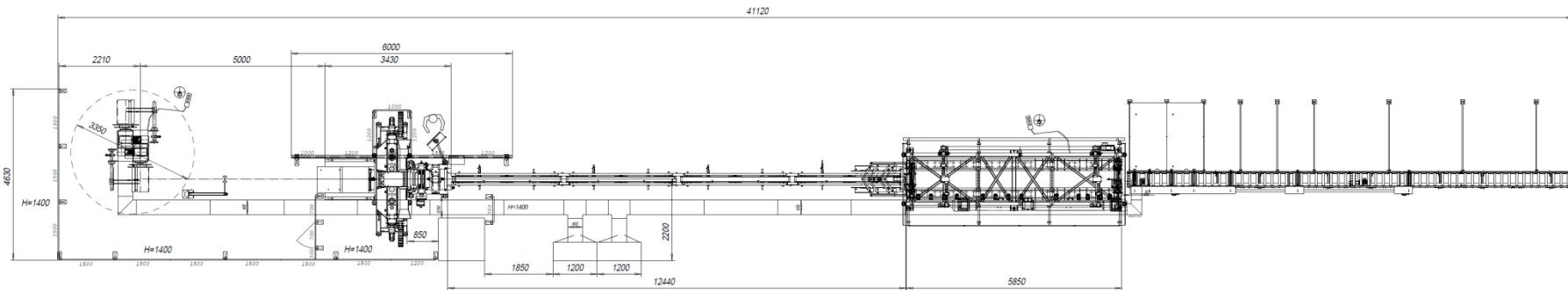

Lay-out sample above: *Prefab Advanced*

Samesor PreFab production solutions for Steel Framing (LSF)

+ Samesor PreFab Advanced:

- Residential houses, social premises, module containers, façade elements, ...
- Detailed *C* and *U* members for wall, truss and floor frames
- Automated production. Integrated 3D-Modelling & CAD-CAM system

+ Samesor PreFab Dynamic:

- Compact version C/U line



SAMESOR STEEL FRAMING LINES

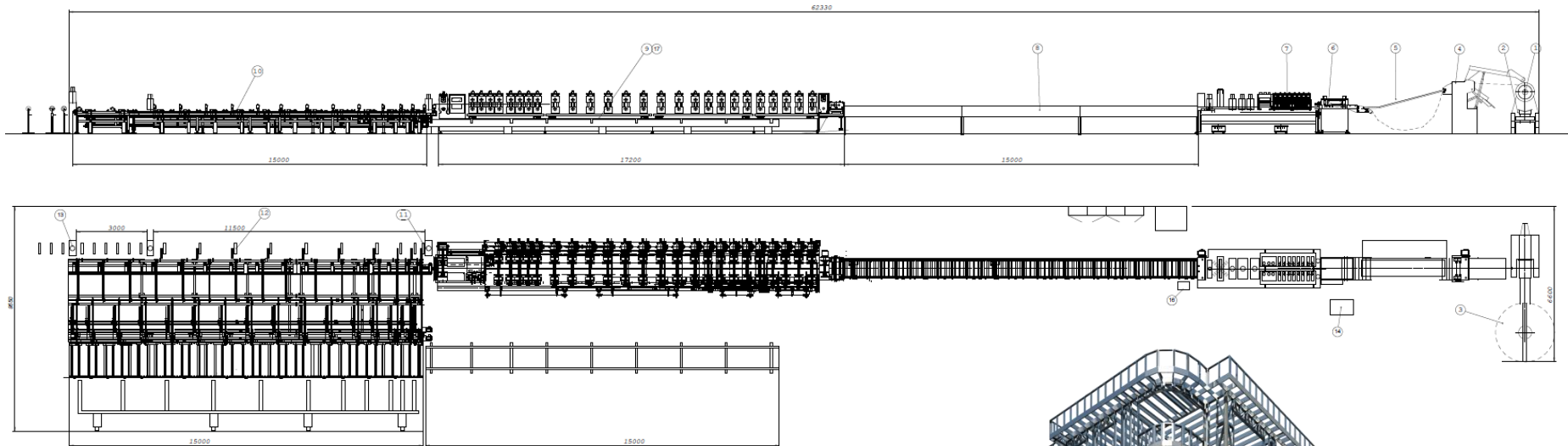

Samesor PreFab production solutions for Steel Framing (LSF)

- ✚ Samesor PreFab Superior: Steel frame & purlin production
 - Industrial buildings, multi-storey buildings, other needs in construction
 - Detailed C, U, Z and Sigma members for wall, truss and floor frames.
 - Automated production. Integrated 3D-Modelling & CAD-CAM production

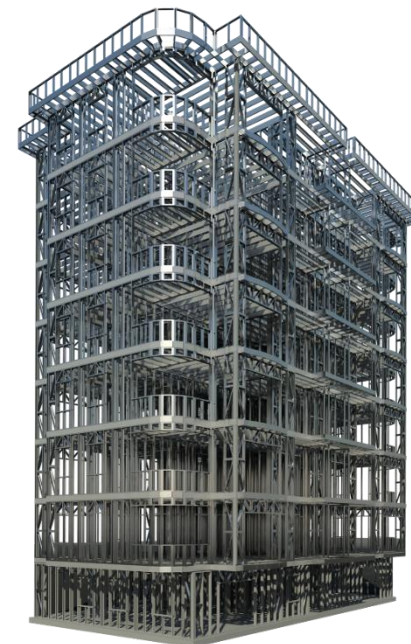

SAMESOR PURLIN LINES

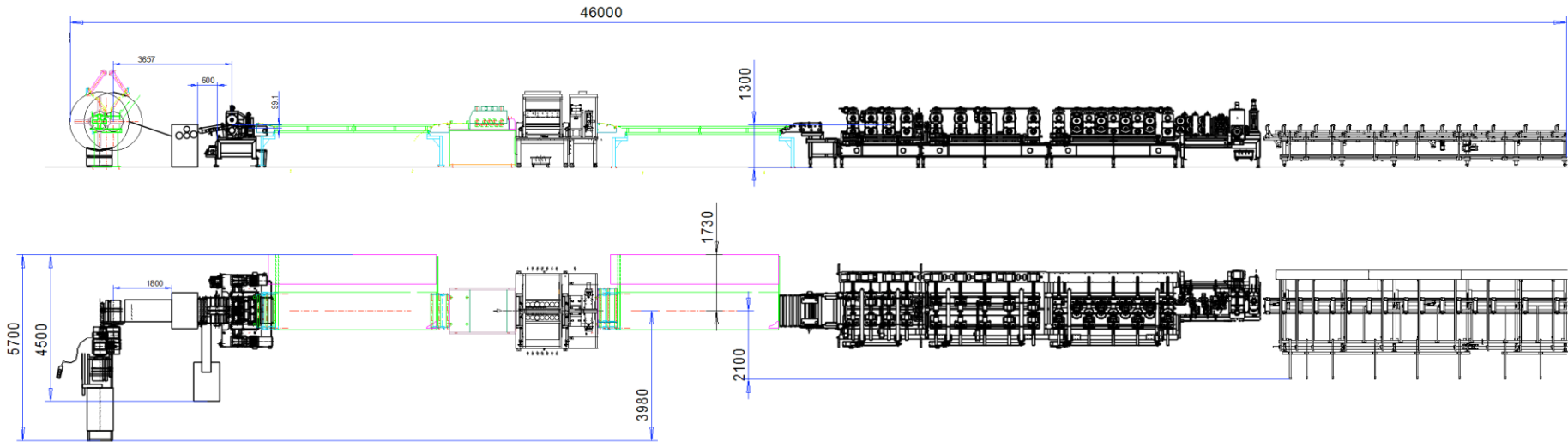

Samesor Purlin Superior production solutions for Steel Framing (LSF)

- Members for primary and secondary structures in industrial construction
- C, U, Z and Sigma profiles. Variable & versatile perforation capability
- Available as Cut-to-Length drive OR Continuous sheet drive version

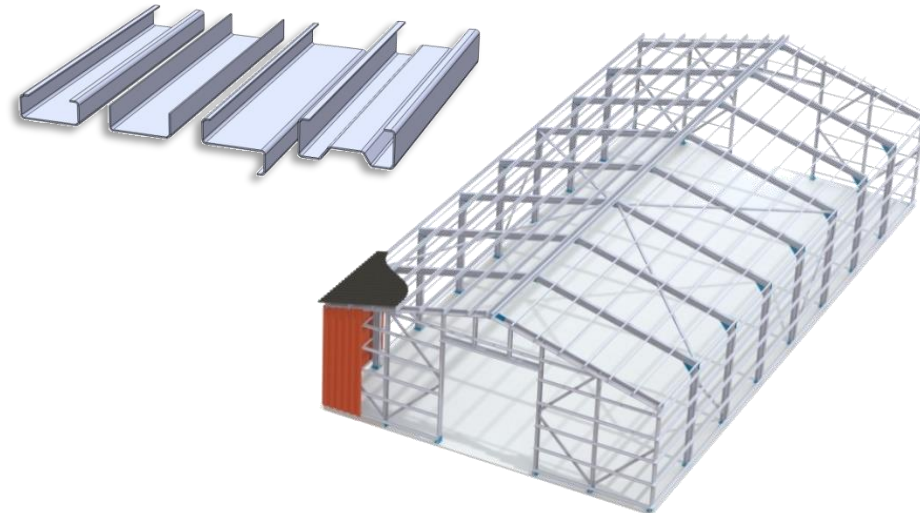

SAMESOR LINES FOR STRIP PRODUCTS & FLASHING

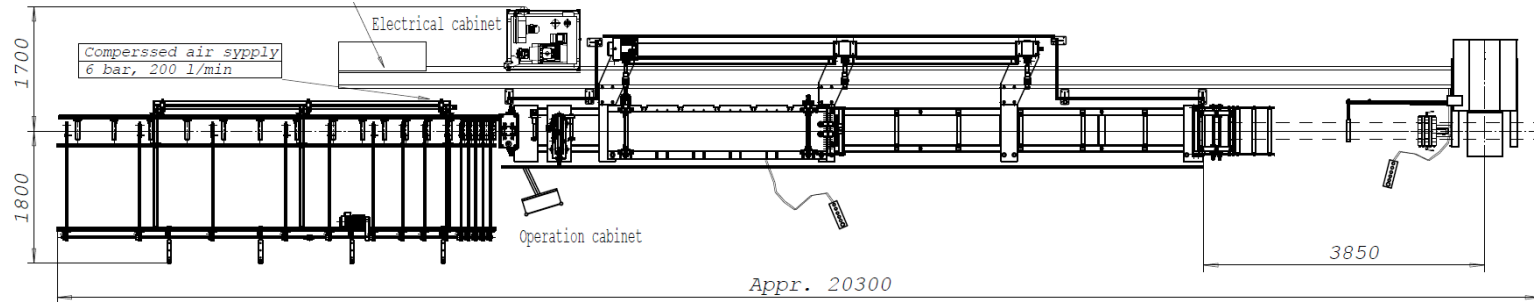

CASSETTES

*Lay-out sample above:
Rafted rollforming line
for Flashings*

Samesor rollforming lines for products like:

- Ridge Cap profiles
- Channel profiles
- Flashings
- Drainage products

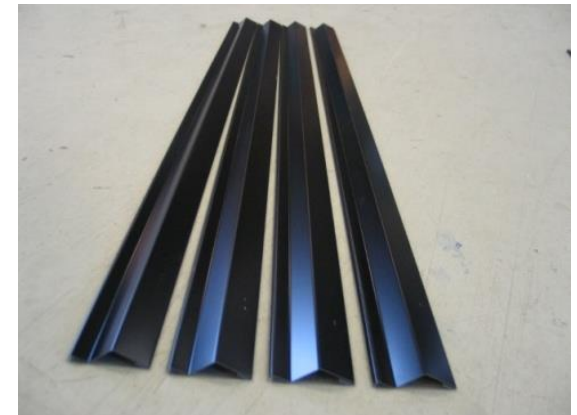
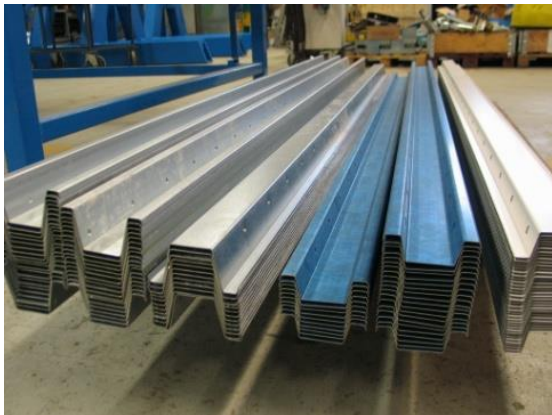

SAMESOR LINES FOR INDUSTRIAL APPLICATIONS

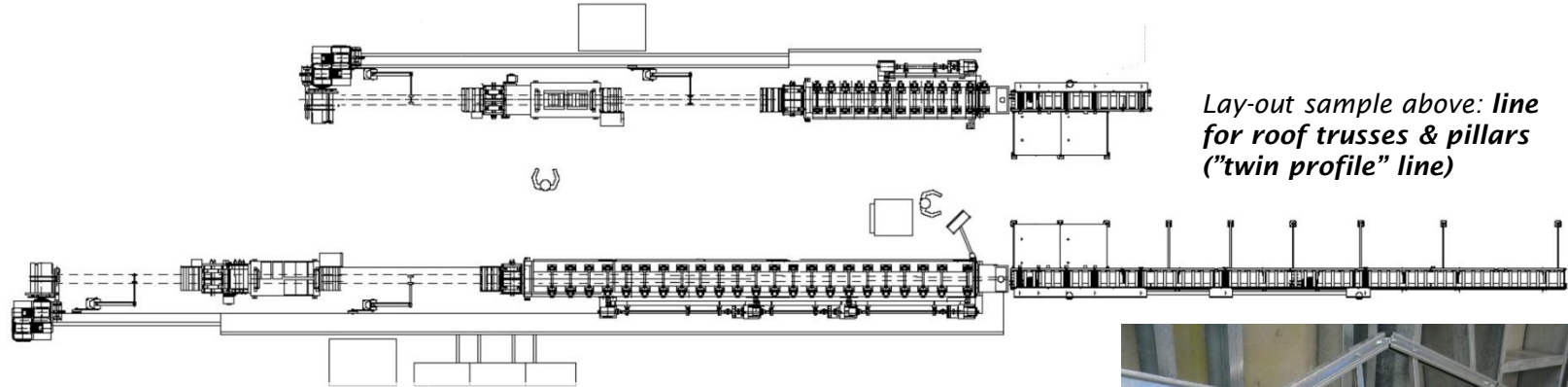

Lay-out sample above: line for roof trusses & pillars ("twin profile" line)

Samesor solutions for various applications, like:

- Members for roof trusses and pillars
- Batten/rib profiles
- Various profile components
- Frame profiles (panel frames, door frames, HVAC)
- Tube casing products



YOUR LINE OUR PASSION

We are pleased to discuss more about your needs!

In addition to mentioned main line types, we are very much able to offer manufacturing solutions for various sheet metal products as well.

Let us put our expertise in sheet metal technology for your success.

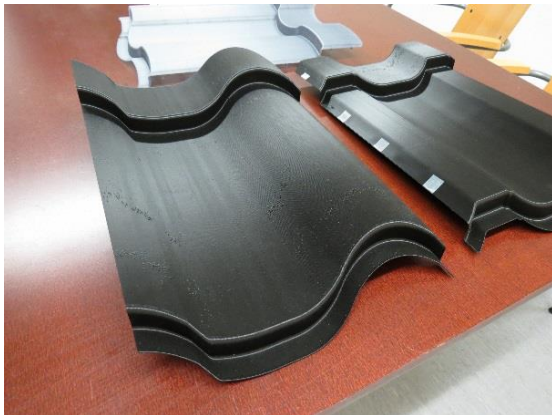
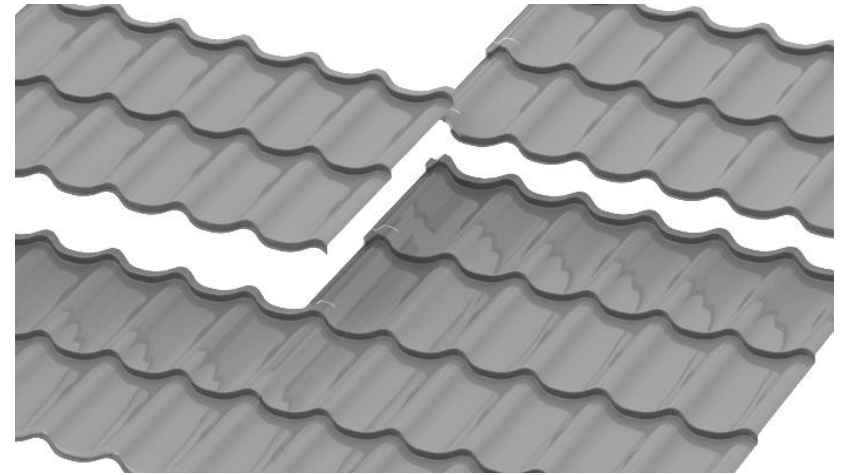



samesor

THANK YOU FOR YOUR INTEREST!

MORE INFORMATION ABOUT US:

www.samesor.fi

SAMESOR OY, P.O.BOX 1406 (MASTOTIE 1), FI-70461 KUOPIO, FINLAND